

APPENDIX B

SUB-DIVISION ROAD CLASSIFICATIONS

Class “A” Road

This roadway is applicable for through township/local roads or when a roadway has high potential to be bituminous surfaced.

- 28 foot graded top width
- 4:1 inslopes
- 3 foot ditch separation
- 6 foot ditch bottom
- 4:1 backslopes
- 4 inch aggregate surface @ 1,825 cubic yards per mile

Class “B” Road

This roadway is applicable for recreational or general development lakes or larger sub-divisions.

- 24 foot graded to width
- 3:1 inslopes
- 2 foot ditch separation
- 4 foot ditch bottom
- 3:1 backslopes
- 3 inch aggregate surface @ 1,170 cubic yards per mile

Class “C” Road

This roadway is applicable for access to Natural Environmental Lakes or small sub-divisions that are not immediately adjacent to other sub-divisions or are connected by another roadway.

- 20 foot graded to width
- 3:1 inslopes
- 2 foot ditch separation
- 4 foot ditch bottom
- 2:1 backslopes
- 3 inch aggregate surface @ 980 cubic yards per mile

Following pages contain Typical Sections of roadways.

IMPROVED ROADWAY TYPICAL SECTION

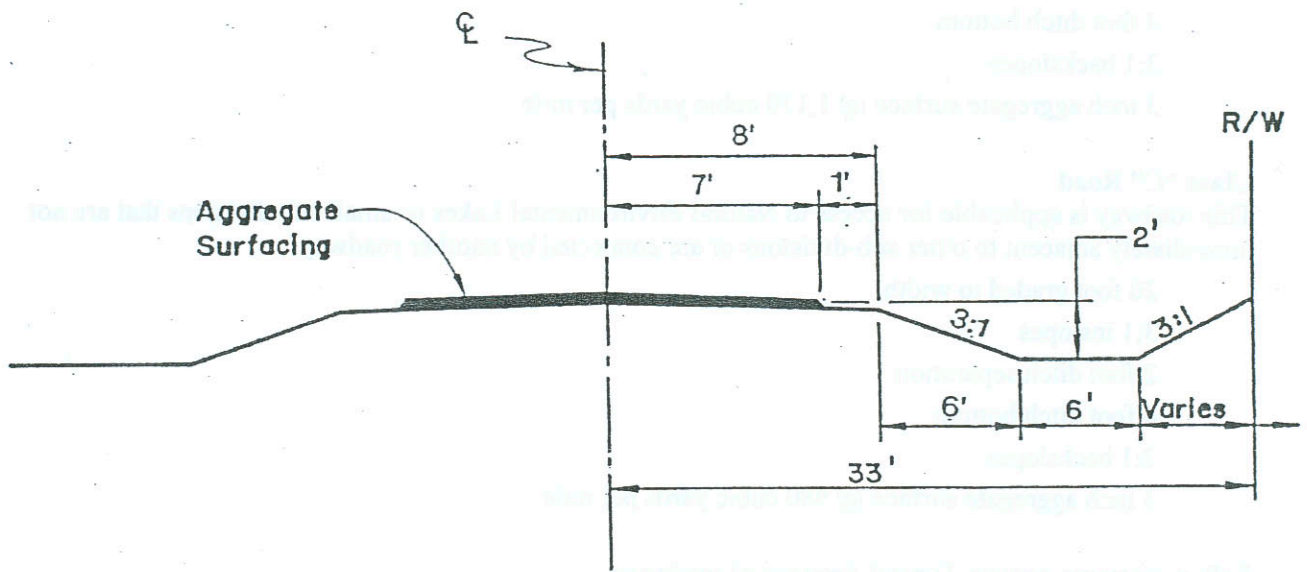

NEW SUBDIVISION ROADS

